

Features

- High isolation 5000 VRMS
- CTR flexibility available see order information
- DC input with transistor output
- Operating temperature range - 40 °C to 110 °C
- REACH compliance
- Halogen free
- MSL class 1
- Regulatory Approvals
 - UL - UL1577
 - VDE - EN60747-5-5(VDE0884-5)
 - CQC – GB4943.1

Applications

- Switch mode power supplies
- Programmable controllers
- Household appliances
- Office equipment



Description

The ICPL-816 series combine an AlGaAs infrared emitting diode as the emitter which is optically coupled to a silicon planar phototransistor detector in a plastic DIP4 package with different lead forming options.

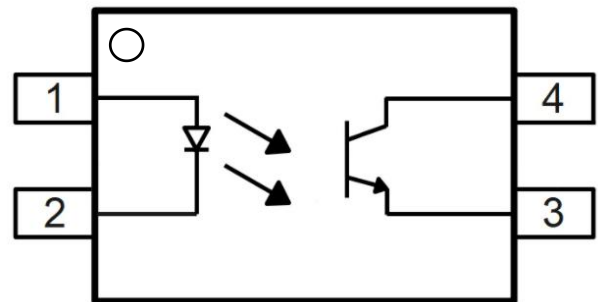
With the robust coplanar double mold structure, ICPL-816 series provide the most stable isolation feature.



ORDERING INFORMATION

Outline	Part Number	Package	Marking	Packing	Packing Size	Quantity
	ICPL-816-01XE	DIP4	ICPL 816X /YYWW A	Tube	500mm	100
	ICPL-816-11XE	DIP4-M		Tube	500mm	100
	ICPL-816-51XE	DIP4-SL		Reel	13 "	1000

CONTENTS

Pin Configuration And Functions.	3
Absolute Maximum Ratings.	3
Electrical Optical Characteristics.	4
Characteristic Curves.	5
Test Circuits.	7
Package Dimensions.	8
Recommended Solder Mask	10
Carrier Tape Specifications	11
Ordering And Marking Information	12
Reflow Information	13
Temperature Profile Of Soldering.	14
Disclaimer	15

PIN CONFIGURATION AND FUNCTIONS

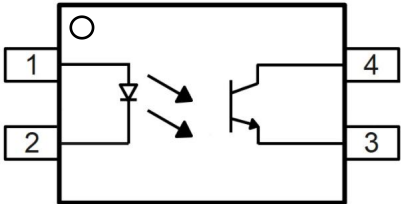
	Pin	Name
	1	Anode
	2	Cathode
	3	Emitter
	4	Collector

ABSOLUTE MAXIMUM RATINGS

Parameter	Symbol	Value	Unit	Note
INPUT				
Forward Current	I_F	60	mA	
Peak Forward Current	I_{FP}	1	A	1
Reverse Voltage	V_R	6	V	
Input Power Dissipation	P_I	100	mW	
OUTPUT				
Collector - Emitter Voltage	V_{CEO}	80	V	
Emitter - Collector Voltage	V_{ECO}	7	V	
Collector Current	I_C	50	mA	
Output Power Dissipation	P_O	150	mW	
COMMON				
Total Power Dissipation	P_{tot}	200	mW	
Isolation Voltage	V_{iso}	5000	Vrms	2
Operating Temperature	T_{opr}	-40~110	°C	
Storage Temperature	T_{stg}	-55~125	°C	
Soldering Temperature	T_{sol}	260	°C	

Note 1. 100 μ s pulse, 100Hz frequency

Note 2. AC For 1 Minute, R.H. = 40 ~ 60%

ELECTRICAL OPTICAL CHARACTERISTICS(T_a=25°C)

Parameter	Symbol	Min	Typ.	Max.	Unit	Test Condition	Note
INPUT							
Forward Voltage	V _F	-	1.24	1.4	V	I _F =10mA	
Reverse Current	I _R	-	-	10	μA	V _R =6V	
Input Capacitance	C _{in}	-	10	-	pF	V=0, f=1kHz	
OUTPUT							
Collector Dark Current	I _{CEO}	-	-	100	nA	V _{CE} =20V, I _F =0	
Collector-Emitter Breakdown Voltage	BV _{CEO}	80	-	-	V	I _C =0.1mA, I _F =0	
Emitter-Collector Breakdown Voltage	BV _{ECO}	7	-	-	V	I _E =0.1mA, I _F =0	
TRANSFER CHARACTERISTICS							
Current Transfer Ratio	None	CTR	50	-	600	%	I _F =5mA, V _{CE} =5V
	A		80	-	160		
	B		130	-	260		
	C		200	-	400		
	D		300	-	600		
	E		100	-	200		
Collector-Emitter Saturation Voltage	V _{CE(sat)}	-	0.06	0.2	V	I _F =20mA, I _C =1mA	
Isolation Resistance	R _{ISO}	10 ¹²	10 ¹⁴	-	Ω	DC500V, 40 ~ 60% R.H.	
Floating Capacitance	C _{IO}	-	0.4	1	pF	V=0, f=1MHz	
Cut-off Frequency	f _c	-	80	-	kHz	V _{CE} =2V, I _C =2mA R _L =100Ω, -3dB	3
Response Time (Rise)	t _r	-	3	18	μs	V _{CE} =2V, I _C =2mA R _L =100Ω	4
Response Time (Fall)	t _f	-	4	18	μs		4

Note 3. Fig.12&13

Note 4. Fig.14

CHARACTERISTIC CURVES

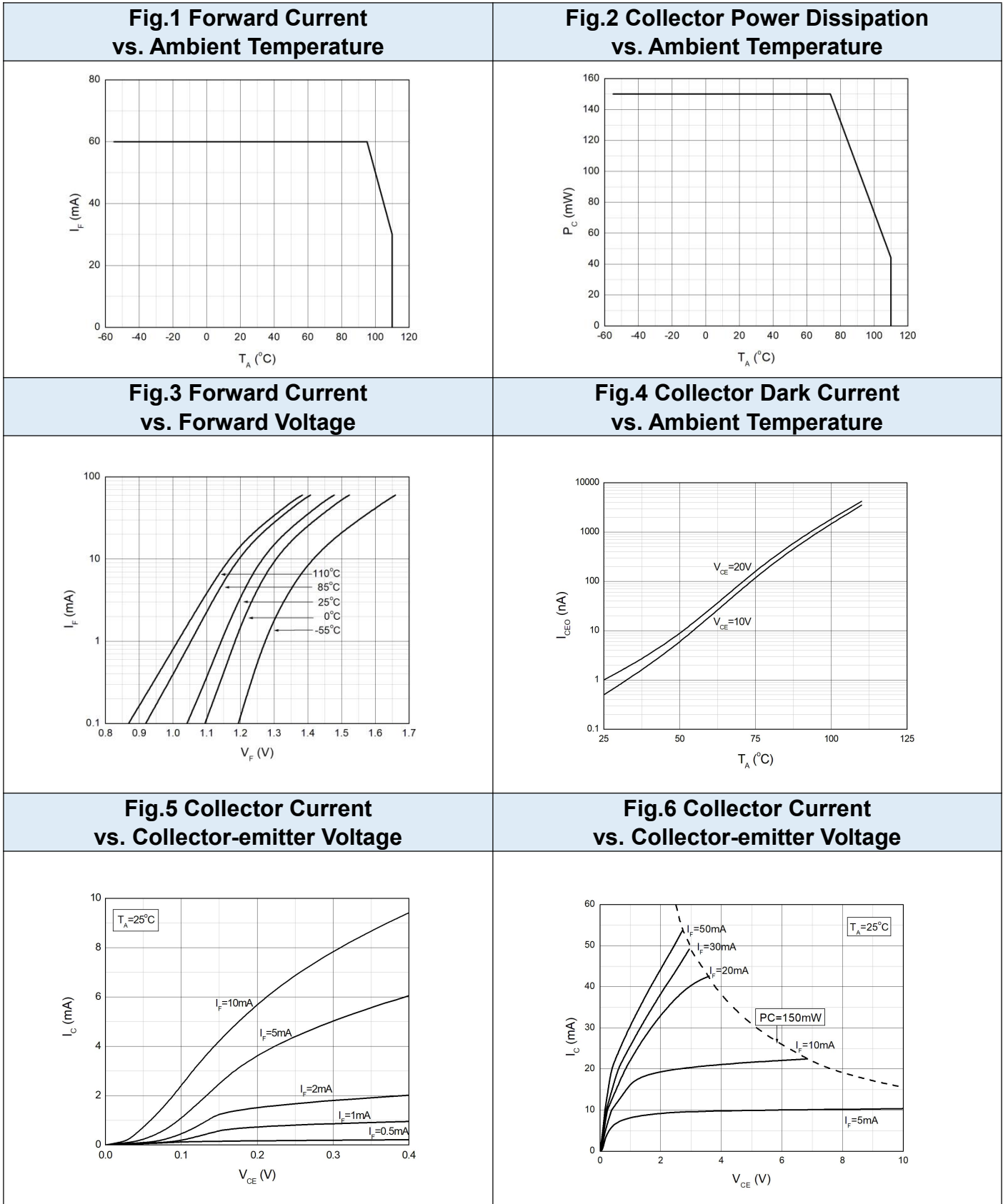

Fig.7 Normalized Current Transfer Ratio vs. Forward Current

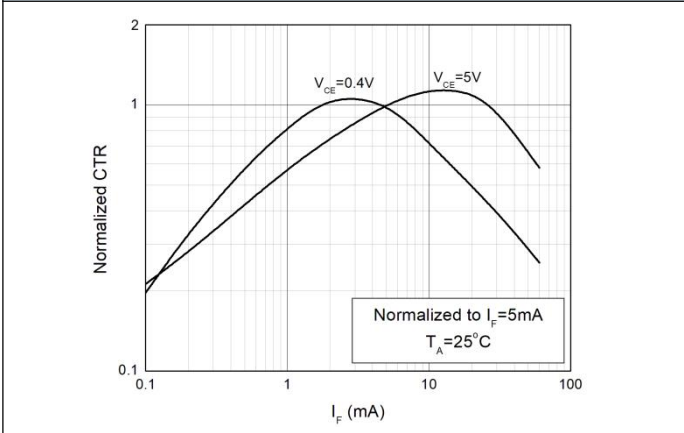

Fig.8 Normalized Current Transfer Ratio vs. Ambient Temperature

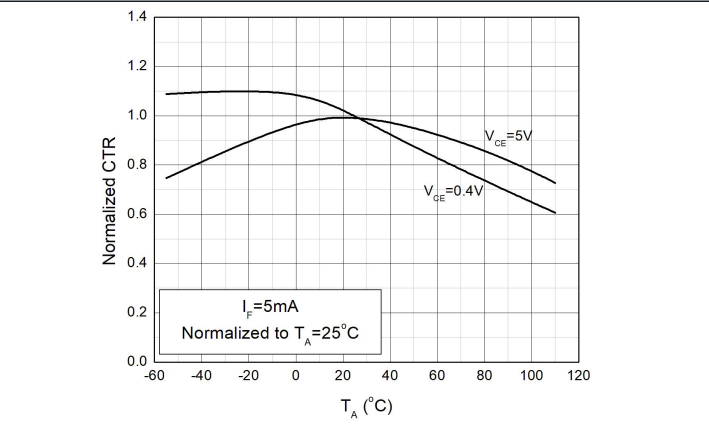

Fig.9 Collector-emitter Saturation Voltage vs. Ambient Temperature

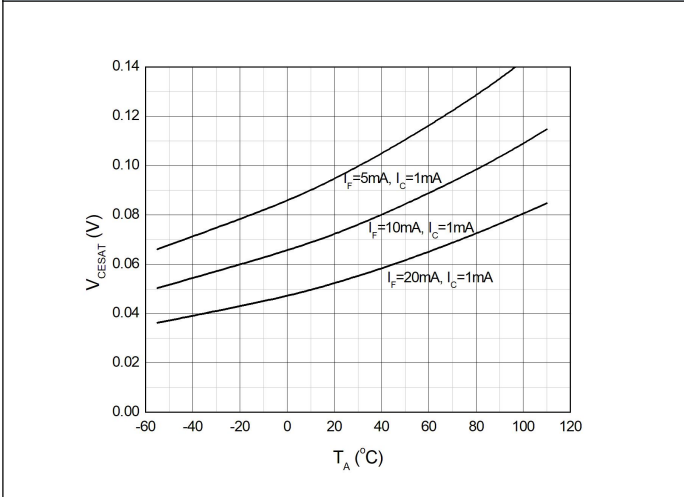

Fig.10 Switching Time vs. Load Resistance

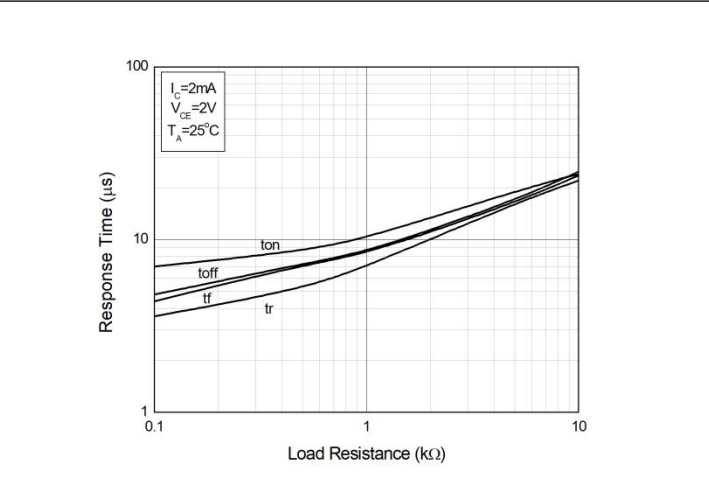
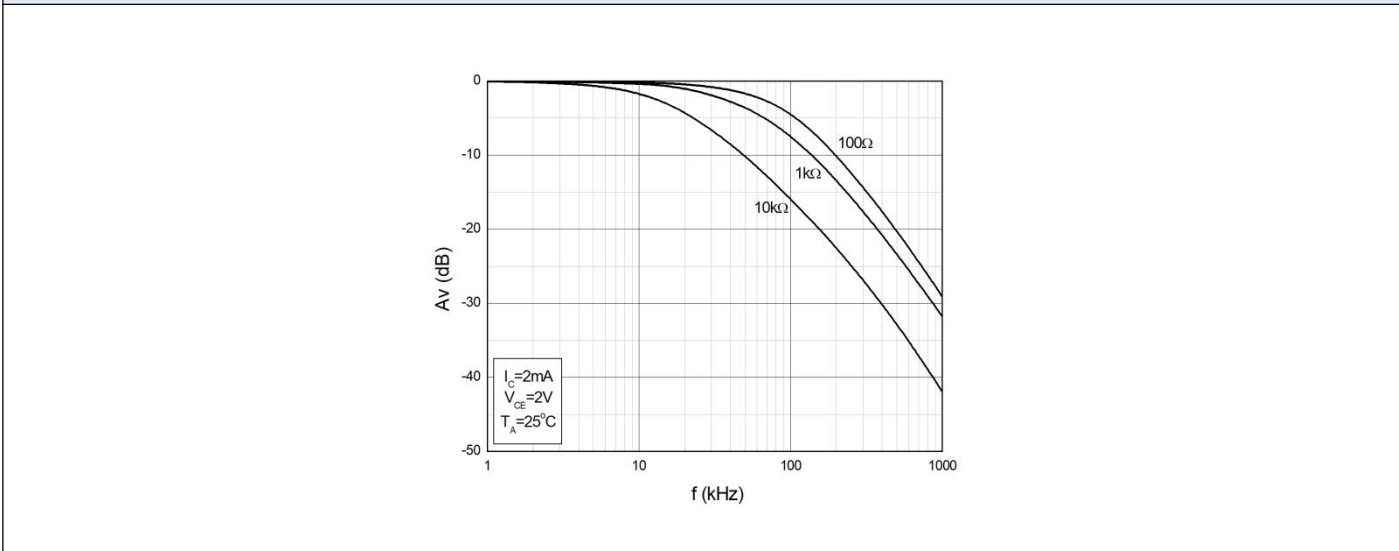
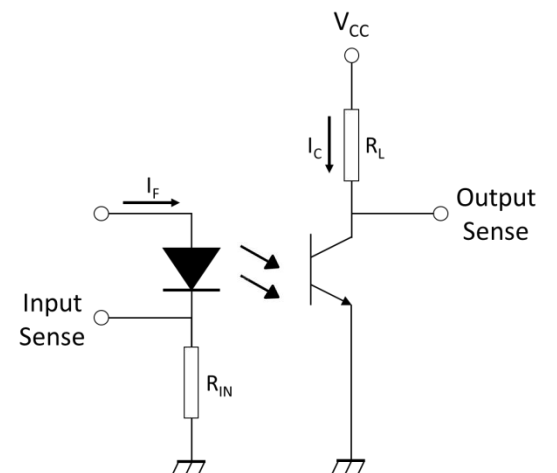
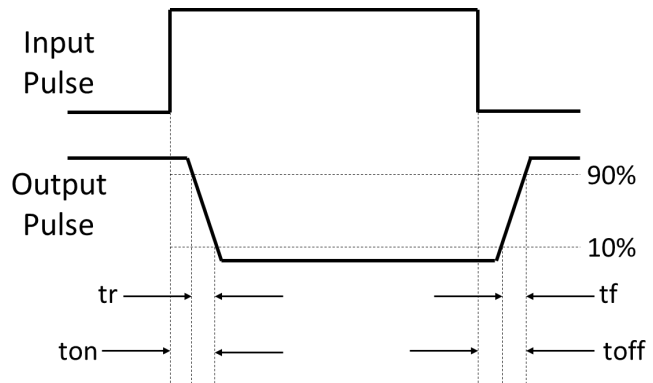
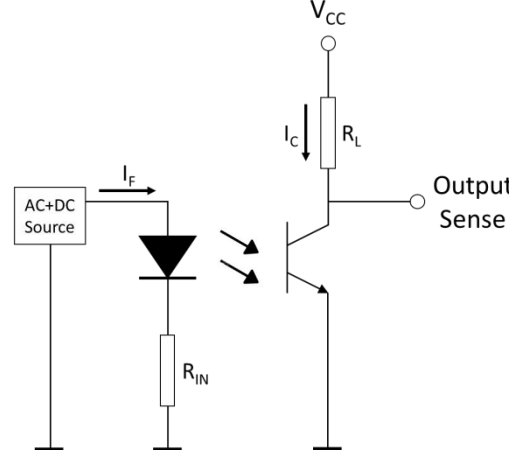

Fig.11 Frequency Response



TEST CIRCUITS

Fig.12 Test Circuits of Response Time	Fig.13 Curves of Response Time
	
Fig.14 Test Circuits of Frequency Response	
	

PACKAGE DIMENSIONS

Standard DIP – Through Hole (DIP Type)

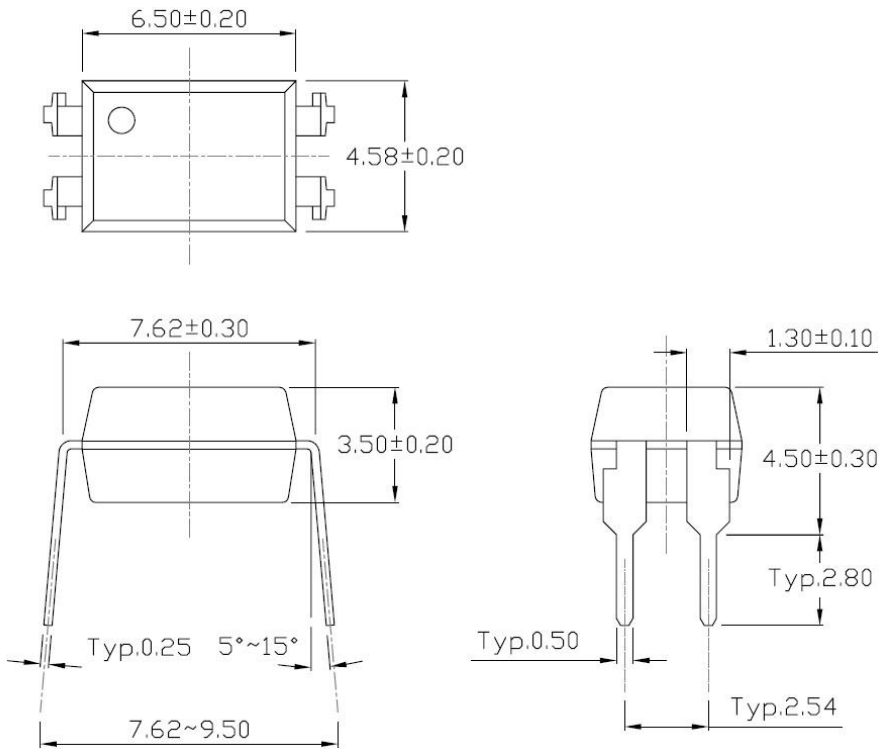

Gullwing (400mil) Lead Forming – Through Hole (M Type)

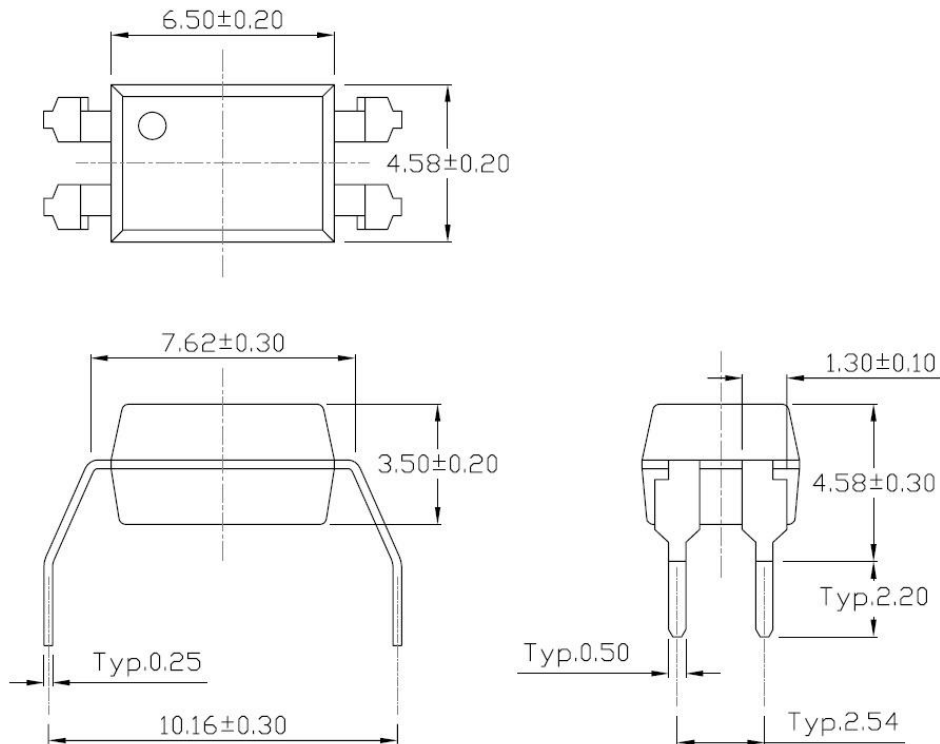

PACKAGE DIMENSIONS

Surface Mount (Low Profile) Lead Forming (SL Type)

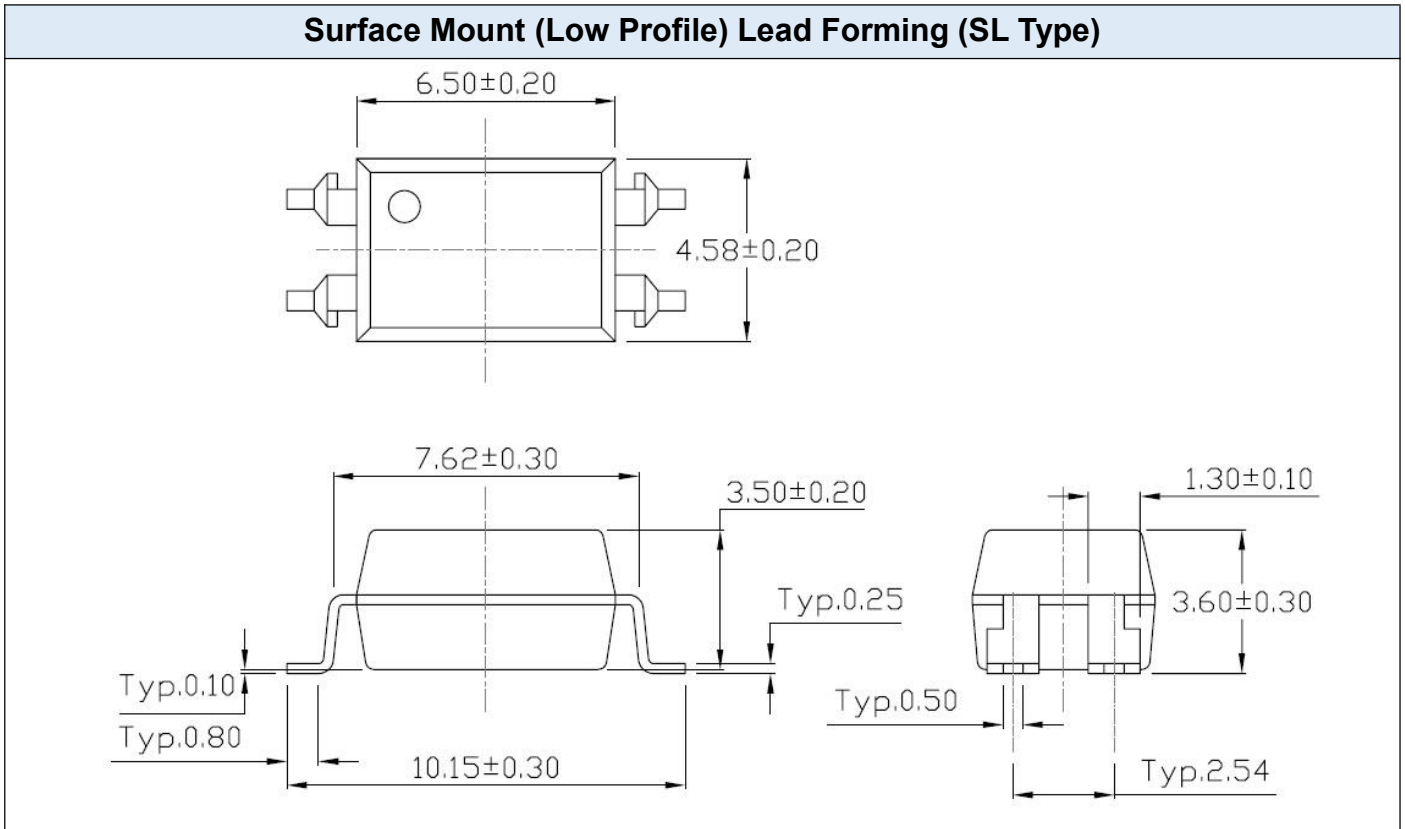

- Dimensions in mm unless otherwise stated

RECOMMENDED SOLDER MASK

Surface Mount Lead Forming & Surface Mount (Low Profile) Lead Forming

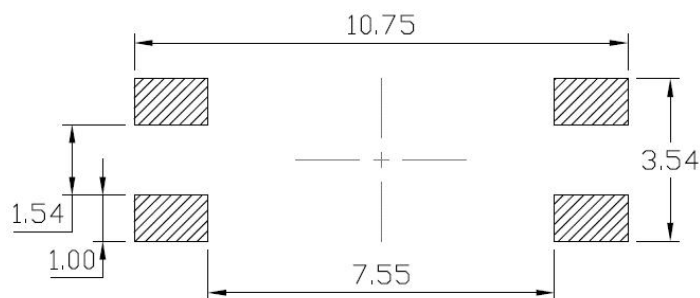

Surface Mount (Gullwing) Lead Forming

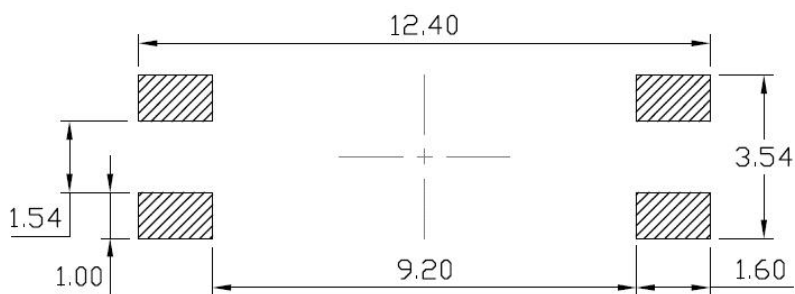

- **Dimensions in mm unless otherwise stated**

CARRIER TAPE SPECIFICATIONS

Option DIP-Standard & DIP-M

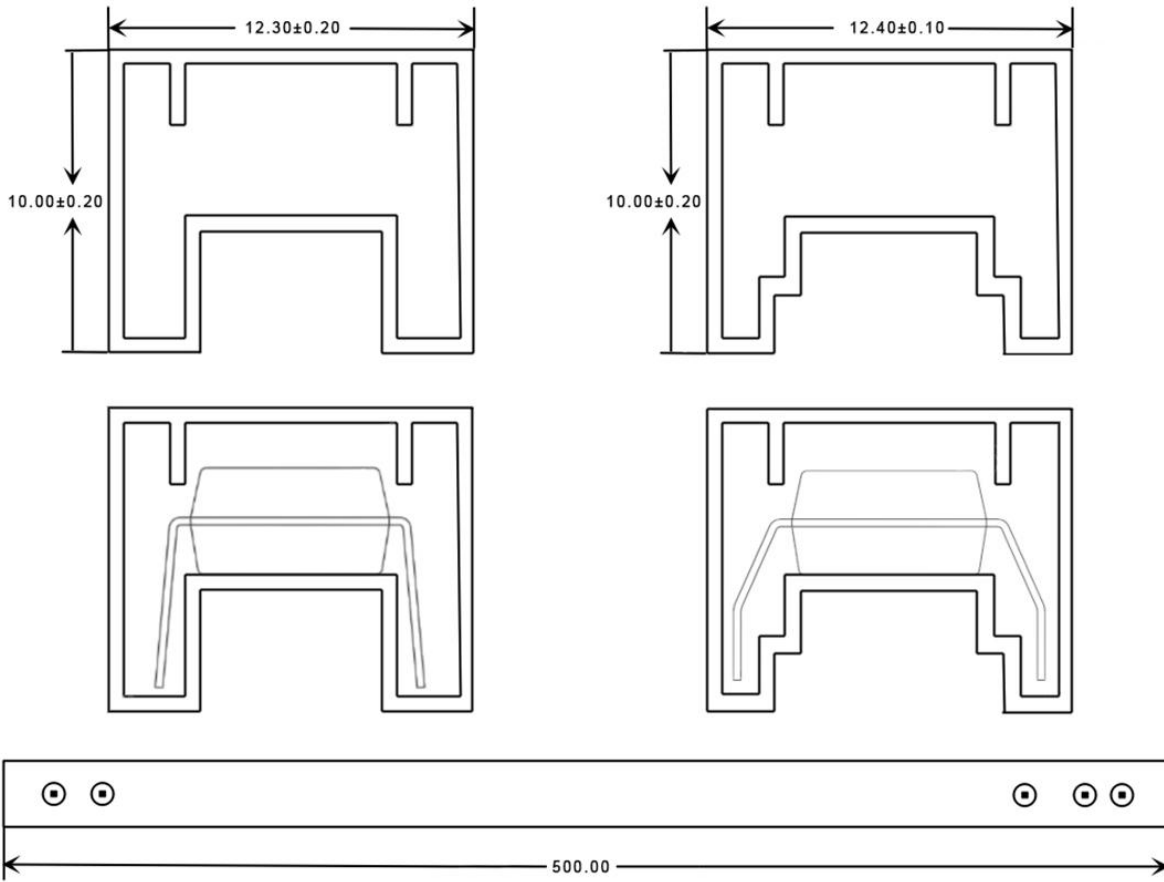

Option SM-SL

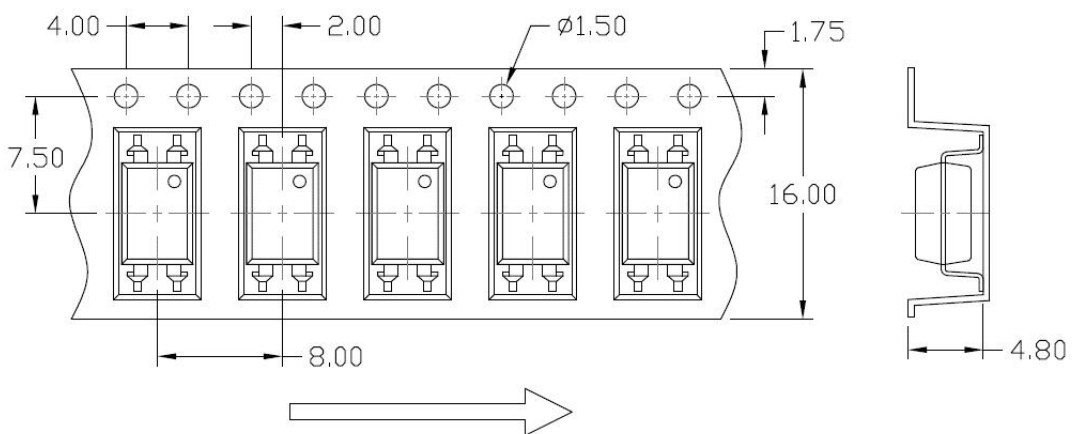

- Dimensions in mm unless otherwise stated

ORDERING AND MARKING INFORMATION

Marking Information



ICPL : Company Abbr.
816 : Part Number
x : CTR Rank
/ : ISOMICRON
YY : Fiscal Year
WW : Work Week
A : Manufacturing Code

Order Code

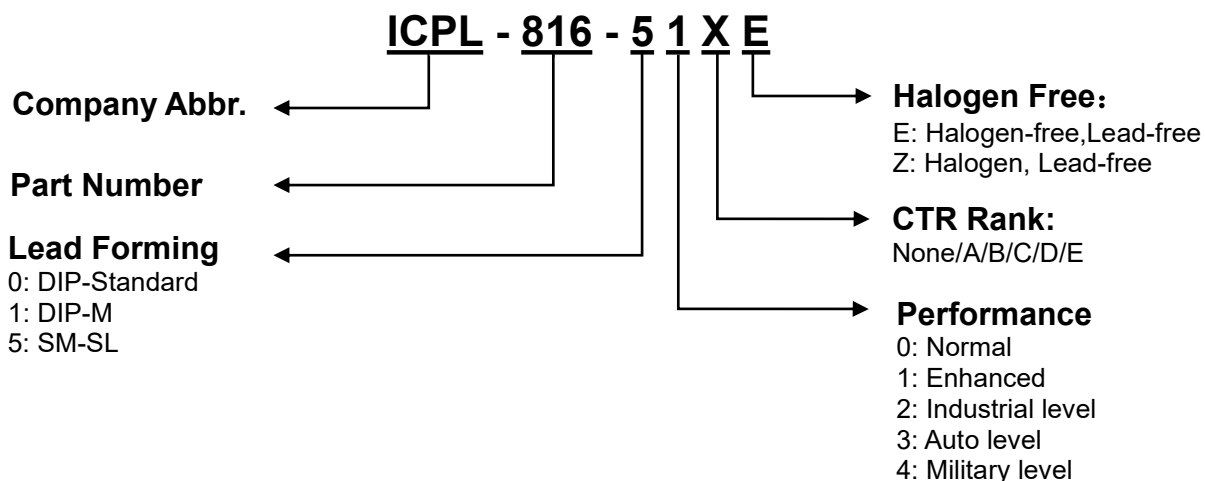

Packing Quantity

Option	Quantity	Quantity – Inner box	Quantity – Outer box
DIP-Standard	100 Units/Tube	20 Tubes/Inner box	6 Inner box/Outer box = 12k Units
DIP-M	100 Units/Tube	20 Tubes/Inner box	6 Inner box/Outer box = 12k Units
SM-SL	1000 Units/Reel	2 Reels/Inner box	5 Inner box/Outer box = 10k Units

REFLOW INFORMATION

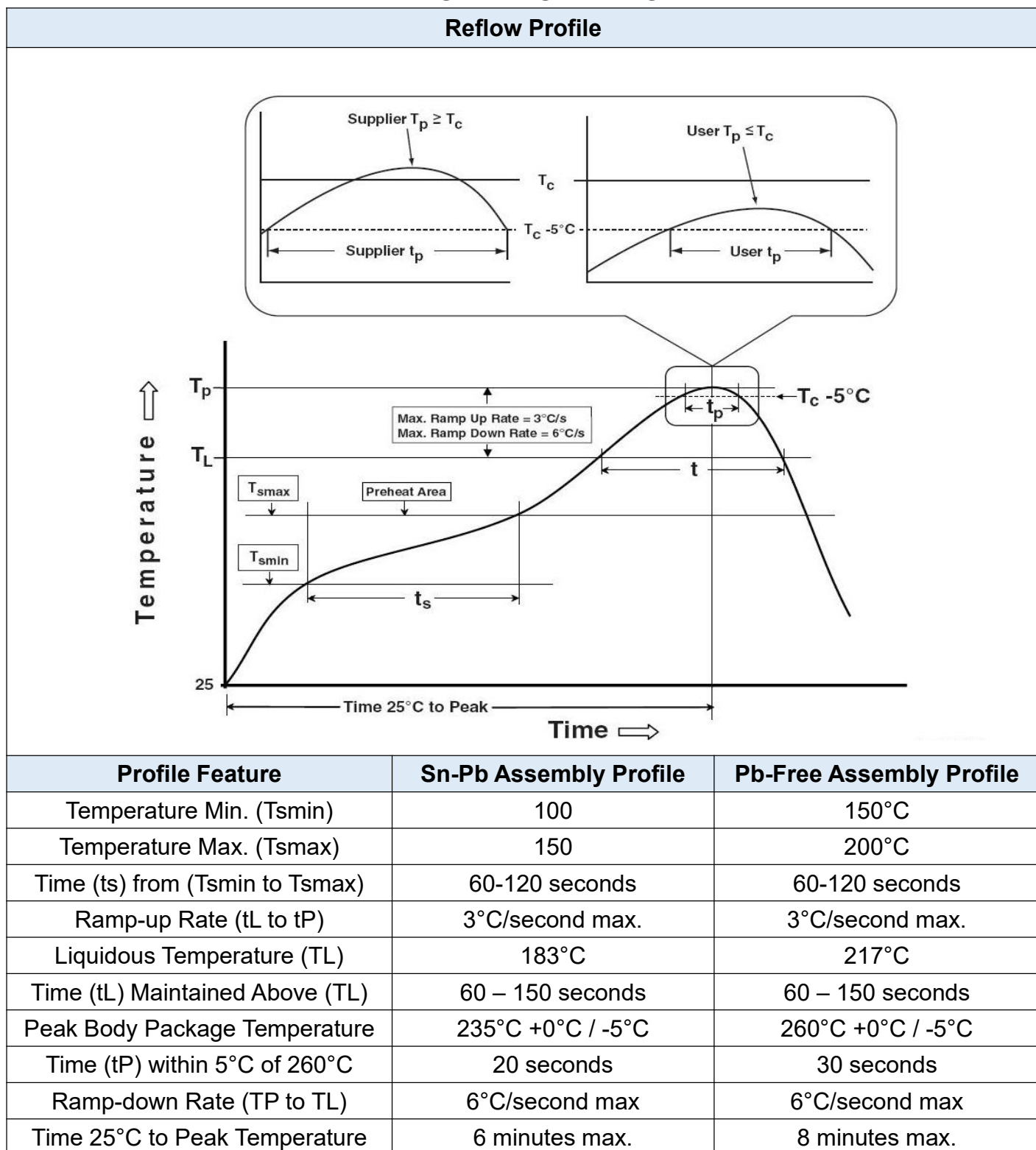

TEMPERATURE PROFILE OF SOLDERING

WAVE SOLDERING (JESD22-A111 COMPLIANT)

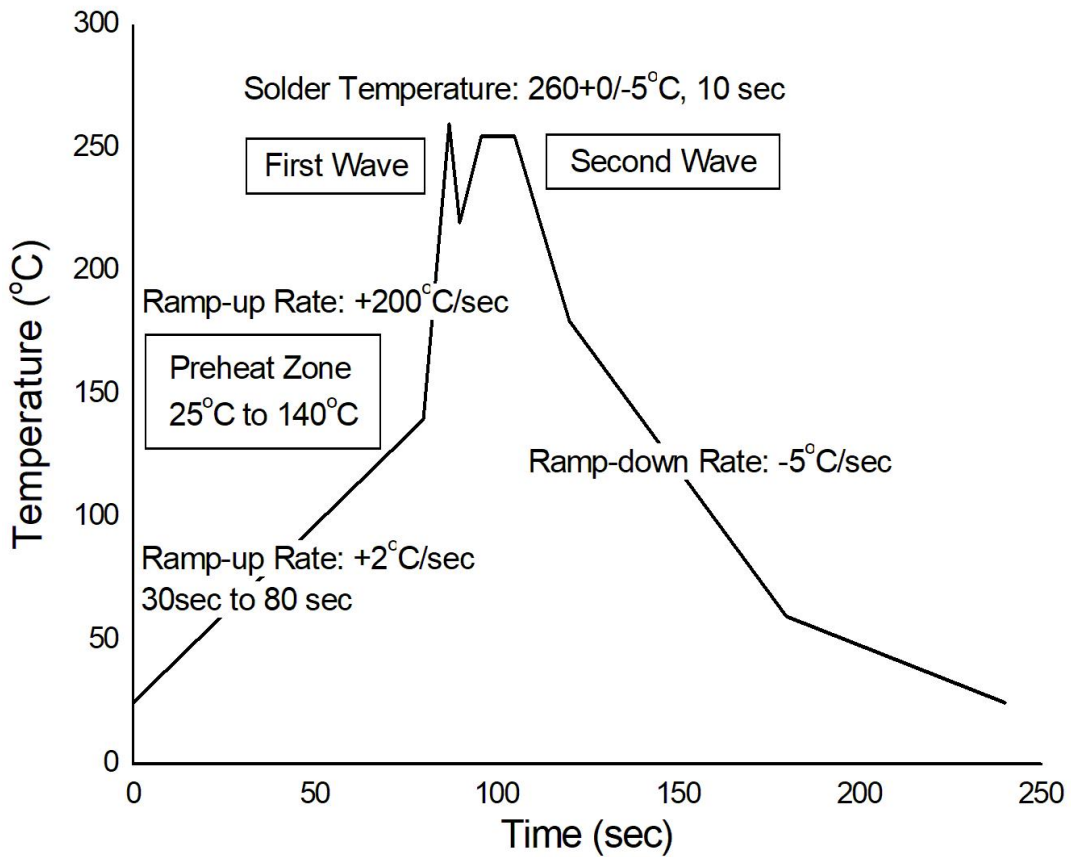

Hand Soldering By Soldering Iron

Soldering Temperature	380+0/-5°C
Soldering Time	3 sec max.

- One time soldering is recommended for all soldering method.
- Do not solder more than three times for IR reflow soldering.

DISCLAIMER

- ISOMICRON is continually improving the quality, reliability, function and design. ISOMICRON reserves the right to make changes without further notices.
- The characteristic curves shown in this datasheet are representing typical performance which are not guaranteed.
- ISOMICRON makes no warranty, representation or guarantee regarding the suitability of the products for any particular purpose or the continuing production of any product. To the maximum extent permitted by applicable law, ISOMICRON disclaims (a) any and all liability arising out of the application or use of any product, (b) any and all liability, including without limitation special, consequential or incidental damages, and (c) any and all implied warranties, including warranties of fitness for particular
- The products shown in this publication are designed for the general use in electronic applications such as office automation, equipment, communications devices, audio/visual equipment, electrical application and instrumentation purpose, non-infringement and merchantability.
- This product is not intended to be used for military, aircraft, automotive, medical, life sustaining or lifesaving applications or any other application which can result in human injury or death.
- Please contact ISOMICRON sales agent for special application request.
- Immerge unit's body in solder paste is not recommended.
- Parameters provided in datasheets may vary in different applications and performance may vary over time. All operating parameters, including typical parameters, must be validated in each customer application by the customer's technical experts. Product specifications do not expand or otherwise modify ISOMICRON's terms and conditions of purchase, including but not limited to the warranty expressed therein.
- Discoloration might be occurred on the package surface after soldering, reflow or long-time use. It neither impacts the performance nor reliability.