

PSMG2.5

Particulate Matter & Gas Sensing Solution

FEATURES

- ✧ Detectable Particle Size ($\geq 0.3 \mu\text{m}$)
- ✧ PWM Output (Low Pulse Occupancy)
- ✧ Excellent Accuracy (LPO)¹⁾
- ✧ Precise PM2.5 level classification
- ✧ High Linearity and Uniformity
- ✧ Market-proven Reliability and Durability
- ✧ High sensitivity for TVOC
- ✧ Gas : Voltage Output

¹⁾ see page 2. Specifications

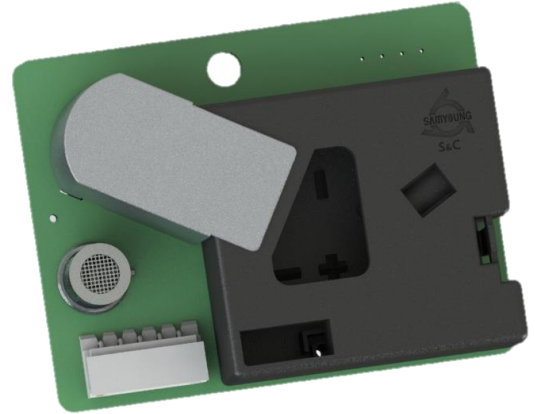

PRODUCT SUMMARY

PSMG Series is PM2.5 & VOCs dedicated sensor providing uniform performance and excellent accuracy in weight concentration value by detecting over $0.3 \mu\text{m}$ sized ultra-fine particle through SAMYOUNG S&C's proprietary optical structure with IrED.

APPLICATION

- Air Solution Products
(Air Purifier, Air Conditioner and etc.)
- HVAC Control System
- Smart IAQ Device
- Outdoor Particle Sensing Device

KEYNOTE

PSMG Series, in which SAMYOUNG S&C's 20years knowledge and technology are concentrated, is a PM2.5 dedicated sensor with a radical improvement for detection capability at ultra-fine particle range – $0.3 \mu\text{m} \sim 1.0 \mu\text{m}$, which enables classifying PM2.5 level more precise than existing sensors.

PSMG Series which performs higher accuracy along with improved sensitivity than conventional sensors provide reliable information to users enabling more accurate and sophisticated control in the applications such as air purifiers, air conditioners and air quality measuring devices.

SAMYOUNG S&C has developed a system to reliably mass-produce PSMG Series of uniform performance by a mass calibration technology which also contributes to efficient production. Moreover, the patented aerodynamic optical structure maximizes the performance of the sensor and improved the quality of the product. In addition, it is designed to be pin-to-pin compatible with existing sensors for user convenience.

Version 1.0 / 2019

1. Product Specification

Ta=25°C

Parameter		Index
DUST SENSOR	Detectable Size	≥0.3 μm
	Effective Range	0~500 μg/m³
	Maximum Range	0~900 μg/m³
	Accuracy	±25%@100~500 μg/m³ ±2.5(LPO)@0~100 μg/m³
	Time for Initial Stabilization	60sec. after powered on
	Response Time	1sec
	Output Signal	LPO (Low Pulse Occupancy)
	Light Source Life Time	Min. 5years
VOC SENSOR	Heater Resistance	46±4 Ω
	Detecting Range(Normal condition)	Max. 100 ppm
	Sensor Resistance(Rs @ in Air)	5~35 kΩ
	Load Resistance(RL)	Typ. 10 kΩ
	Detecting Output Voltage	RL / (Rs + RL) * Vcc (V)
Supply Voltage		DC5.0V±10% Ripple 30mV 이하
Current Consumption		Typ. 170mA
Operating Temperature		-10~50°C
Operating Humidity		5%RH~95%RH(Non-Condensing)
Storage Temperature		-20~70°C
Storage Humidity		5%RH~95%RH (Non-Condensing)
Dimension		59 x 45 x 17mm (W x H x D)
Weight		26g

2. Pin Map

Pin No.	Name	Description
1	GND	Ground
2	VOC	VOC
3	VCC	DC 5V
4	TX	PM2.5 PWM
5	OPT	Not Used (N.C)

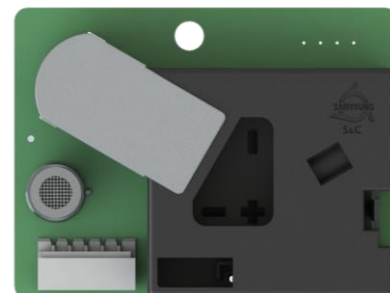

⑤④③②①

Version 1.0 / 2019

3. Output Characteristics

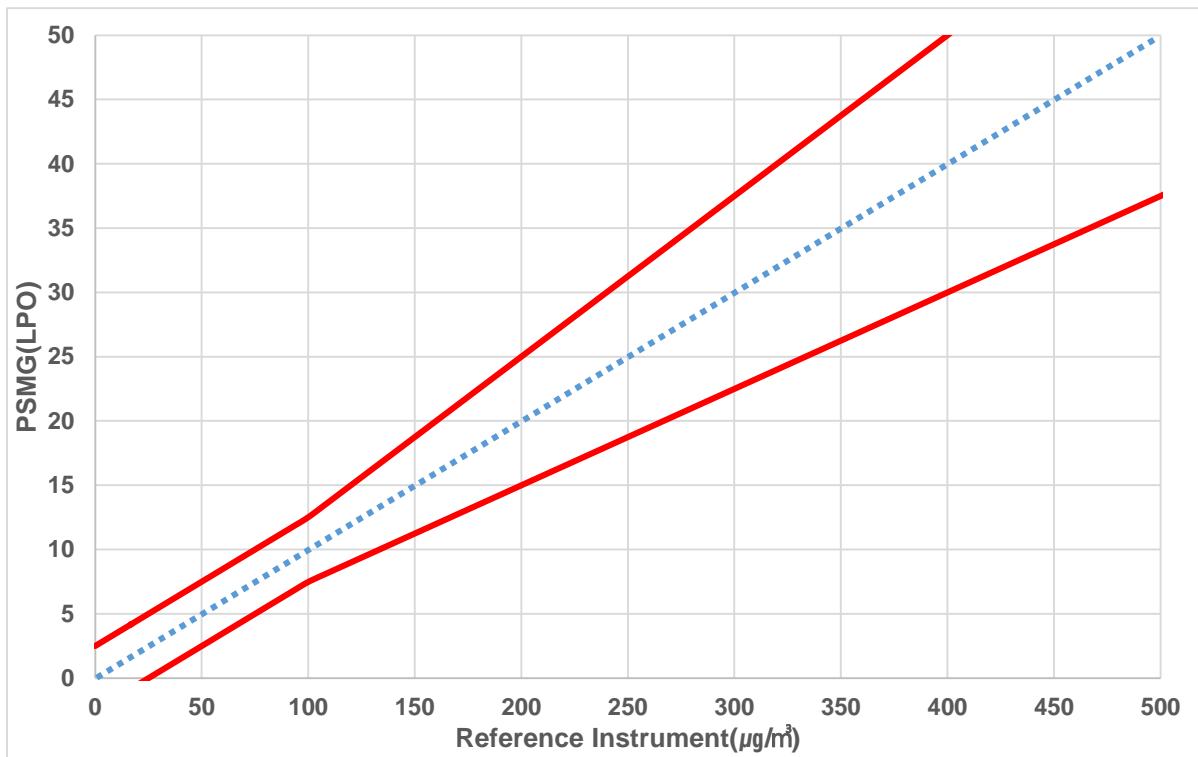

Figure1. Output Characteristics

*see 4. Standard Measurement Method for referential testing method

4. Standard Measurement Method

- ◆ Room Chamber : 27 m³ @23±5°C, 50%RH
- ◆ Particle Source : Cigarette
- ◆ Reference Instrument : GRIMM 11-A
- ◆ Particle Saturation Time : 5mins
- ◆ Measurement Time : 60mins
- ◆ Sensor Placement : Center of Room Chamber

Spray cigarette smoke in room chamber, and measure weight concentration of the airborne particles while slowly purifying the air inside the chamber through HEPA filter.

Version 1.0 / 2019

5. Internal Schematic

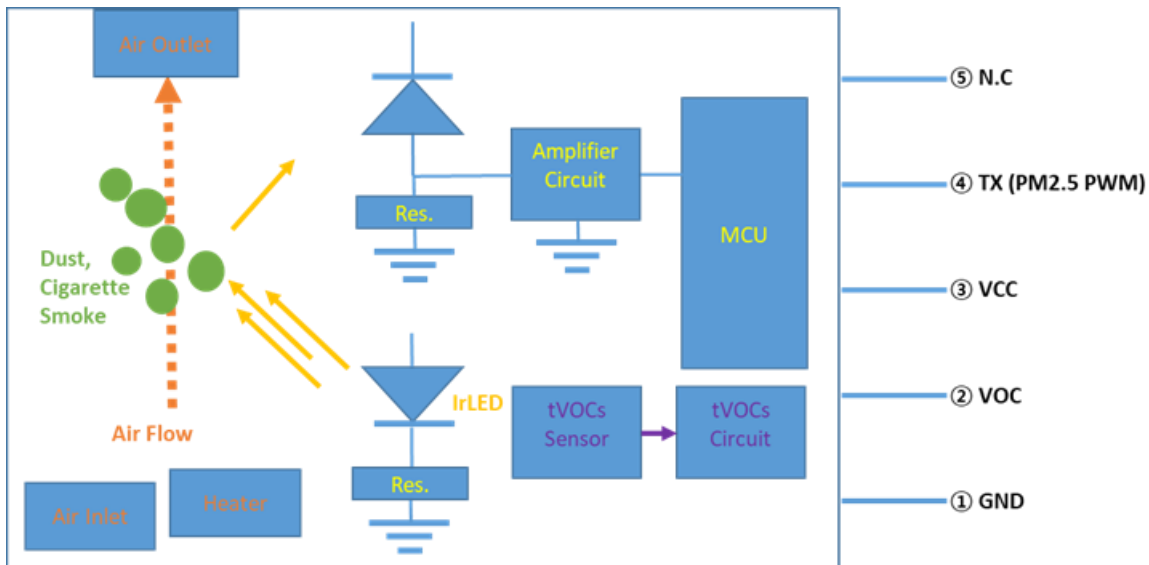

Figure2. Example of Internal Schematic

6. I/O Connector Specifications

Pin No.	Name	Description	Remark
1	GND	Ground	Ground
2	VOC	VOC	VOC Voltage
3	VCC	DC 5V	Input Voltage
4	TX	PM2.5 PWM	PM2.5 PWM Output
5	OPT	Not Used (N.C)	Not Connected

7. Connector Description (Male/Female)

Model Name	Part No.		Description	Connector Maker
PSMG2.5	Wafer	YMAW-025-05	2.5mm pitch	Yeonho Electronic
	Housing	YMH025-05R		

8. Interface Circuit

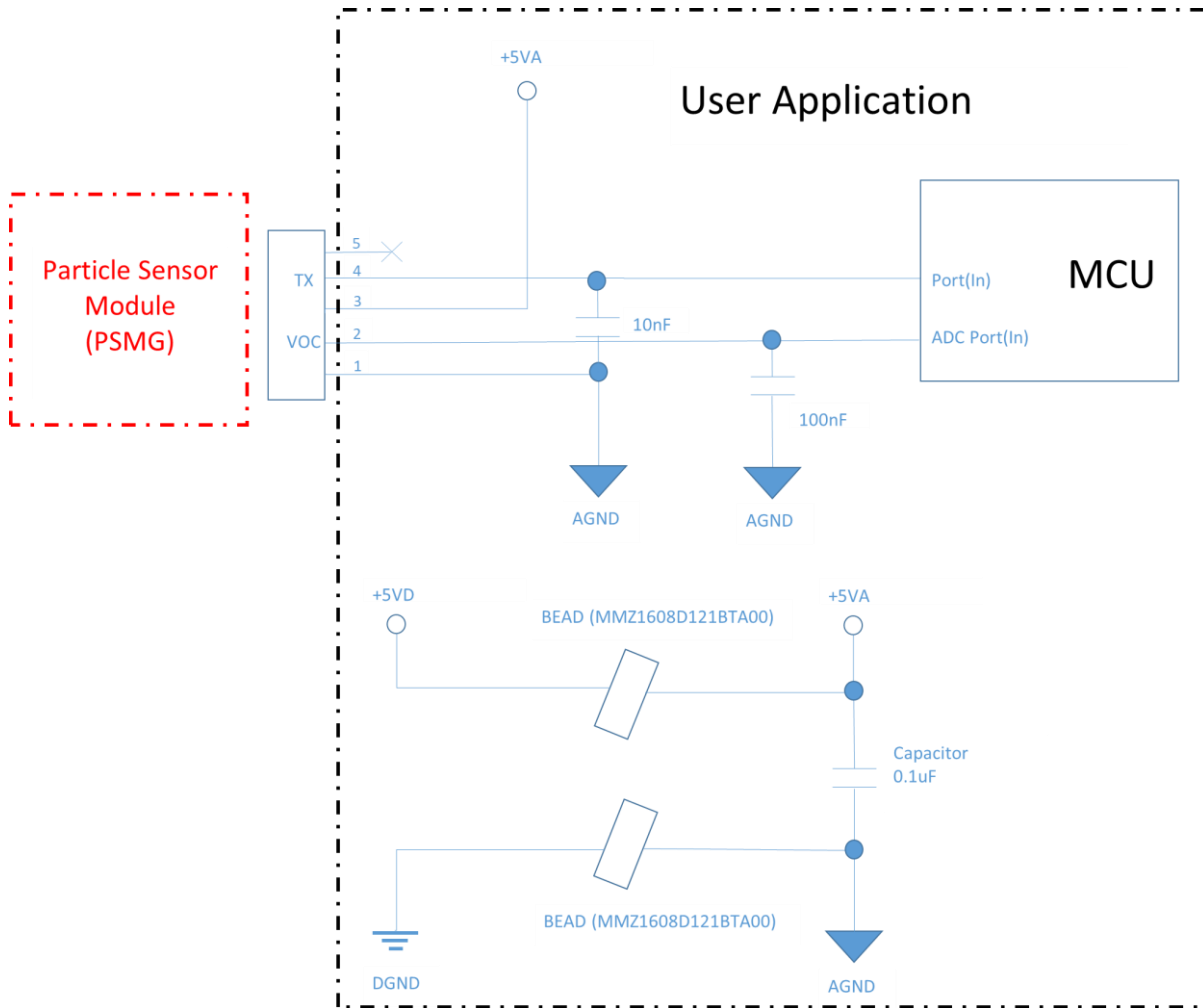

Figure3. Example of Interface Circuit

*Please use an extra power regulator and/or a bypass capacitor(below 10 nF) on the signal line in order to compensate noise if there is noise on the signal, or power line and/or signal line are longer than 50 ㎝.

9. Output Signal (Tx)

9.1. LPO Output (PWM)

Properties	Value
Period	100 ms
Duty Cycle	0%($\mu\text{g}/\text{m}^3$) ~ 95%(950 $\mu\text{g}/\text{m}^3$)
Polarity	Active Low
Resolution	0.1 ms (about 1 $\mu\text{g}/\text{m}^3$)
Update Cycle	about 1 sec

10. Particle Concentration Calculation

$$\text{Particle Concentration}(\mu\text{g}/\text{m}^3) = (T_1 + T_2 + T_3 + \dots + T_N) \times 100 / \text{Period} / N \times 10$$

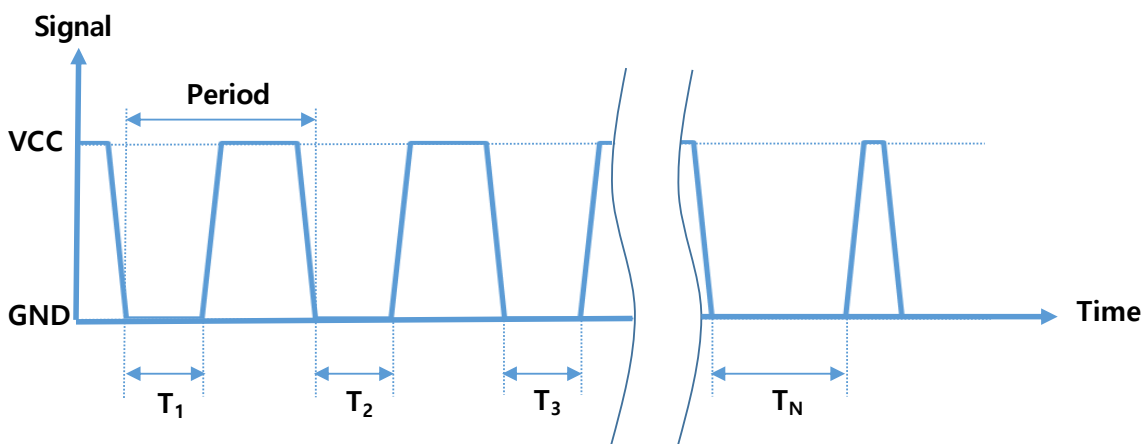
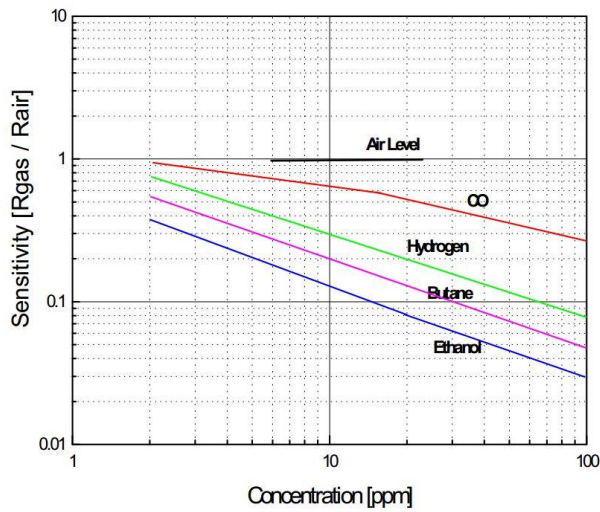

Figure.4 Dust Sensor Low Ratio

11. Gas Sensor Characteristics



Rair : Resistance Values in the Air

Rgas : Resistance Values in the Air per Gas

* Measuring conditions : 24°C, RH50%

Figure5. Sensitivity Characteristics of Gas Sensor

Refer to the attached additional 'Application Note' for the method of signal conditioning of gas sensor.

12. Dimensions

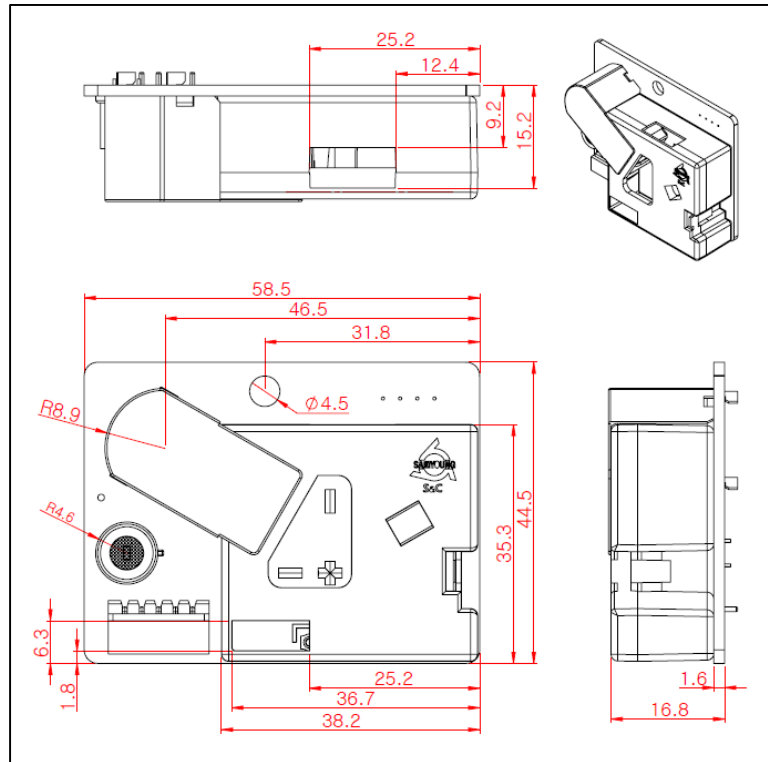

Figure6. Dimensions

13. Ordering Information

Type	Part No.	Contact Info.	
PM2.5 & Gas	PSMG2.5	E-MAIL	sales@samyoungsnc.com
		PHONE	+ 82 31 780-9900

14. Packaging Information

Tray : 25pcs / 1 Tray (PS, 365×300×25 mm) Out Box (KBL3SK, 380×320×255 mm) : 10 Trays (250pcs, 7.85kg)

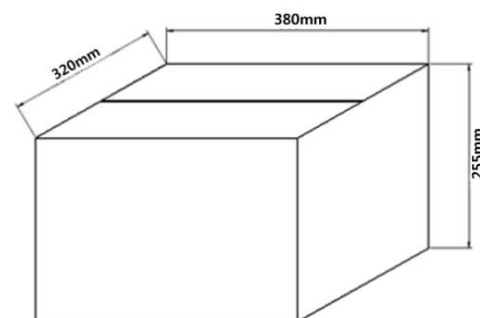
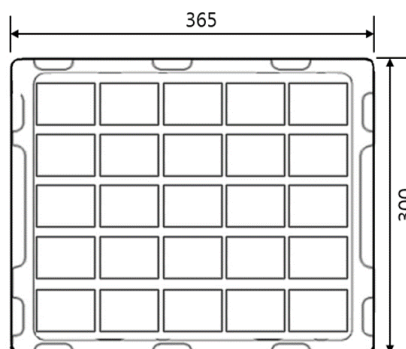

Version 1.0 / 2019

15. Revision History

Date	Version	Page	Change
2019.04.18	Ver.1.0		First Release