



OXYGEN | H₂S | MOISTURE

THE LEADER IN ANALYZERS FOR NATURAL GAS

COMPLETE GAS ANALYZER SOLUTIONS

Advanced Micro Instruments offers a full-line of advanced Gas Analyzers for detecting oxygen, hydrogen sulfide and moisture in Natural Gas. In addition to our fixed and portable Analyzers, we offer a range of maintenance-free accessories that protect the Analyzers from the harsh elements found in natural gas pipelines.

INDUSTRY PROVEN EXPERTS

AMI has been supplying the Natural Gas Industry with Gas Analyzers since 1995. Our Analyzers are found on compressor stations, meter runs, VRU's, gas processing plants and other gas infrastructure across North America. When the measurement is critical, the industry trusts AMI's Gas Analyzers to get the job done right – every time.

TECHNOLOGY LEADERS

AMI's patented designs and unique, proprietary technologies give customers industry-leading performance, reliability and accuracy. Our Gas Analyzers are packed with highly desirable features that provide operators with ultimate flexibility in monitoring their gas conditions while minimizing the Analyzer

iSweek www.isweek.cn

公司名: 深圳市工采网络科技有限公司

电话: + 86-755-83289069

地址: 广东省深圳市南山区高新南一道中国科技开发院3号楼16层

传真: + 86-755-83289052

邮箱: sales@isweek.cn

BX Series

AMI's BX Series is our most advanced offering of High-Performance Analyzers. They combine patented technologies with reliable and easy-to-use, intuitive features and are the preferred choice among engineers and measurement technicians.

OXYGEN (O₂)



MODEL 2010BX
TRACE OXYGEN
10 Output Ranges
PPM and % Level

Industry's best selling Analyzer for detecting trace levels of oxygen in Natural Gas. Fast, accurate measurements down to 0.05 ppm.



MODEL 1000RS
PORTABLE TRACE OXYGEN
10 Output Ranges
PPM and % Level

Ultra-portable O₂ Analyzer for spot-checking pipelines. Patented 4-way Selector Valve (Sample/Purge/On/Off) allows for rapid come down time between measurements.

MODEL 210BX
PERCENT OXYGEN
4 Output Ranges
Ranges between 0-25%

Designed for detecting percent level of oxygen in gas streams down to 0.01%.



HYDROGEN SULFIDE (H₂S)



MODEL 3010BX
TRACE H₂S
4 Output Ranges: 0-200 ppm
Optional Ranges: 0-2000 ppm

Compact, low-cost design for continuous measuring trace levels of H₂S in natural gas.



MODEL 3000RS
PORTABLE TRACE H₂S
4 Output Ranges: 0-200 ppm
Optional Ranges: 0-2000 ppm

Spot-checking and fast verification of H₂S monitors. High accuracy (± 1%) compared to sample tubes (± 10 to 15%).

MOISTURE (H₂O)



BARRACUDA MODEL 4010BR
Tunable Diode Laser (TDL)
TRACE MOISTURE
RANGE: 0.25 - 20.0 lbs
(5.25 - 420ppm) H₂O

Most advanced TDL Moisture Analyzer in the Industry. Patented design makes the **MODEL 4010BR** highly reliable, very compact and extremely cost-effective. The **MODEL 4010BR** is packed with desirable features while being a

KEY FEATURES

- ▶ Advanced TDL technology makes moisture measurements possible with some of the most difficult gas samples
- ▶ Industry's shortest gas path to the measurement cell means fast, accurate moisture readings
- ▶ Low power requirements allow for AC, DC and remote solar installations

ELIMINATOR CELL BLOCK™

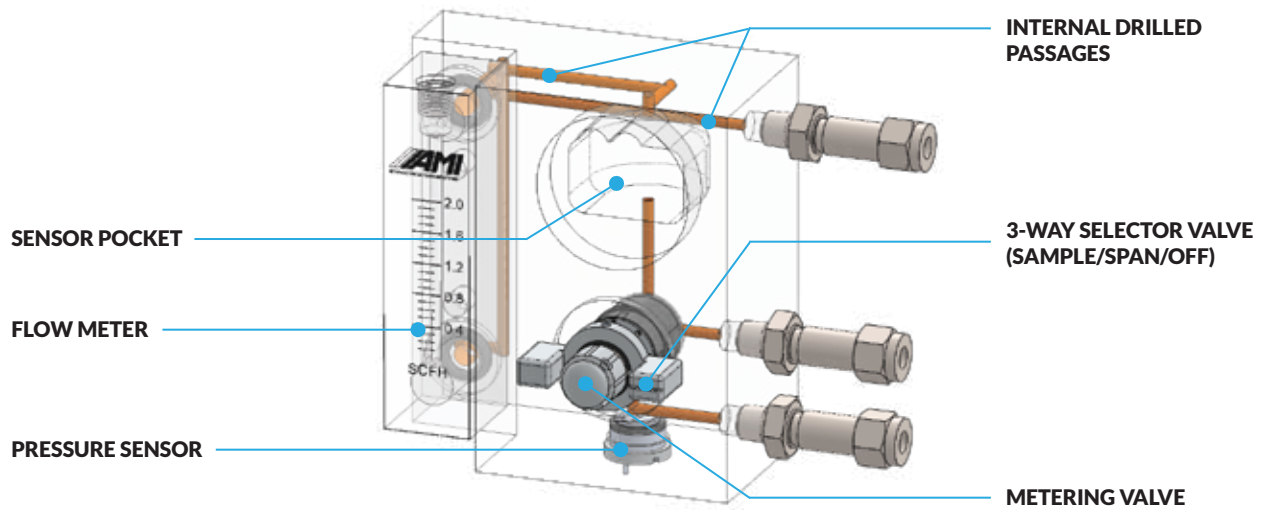

Our patented **ELIMINATOR CELL BLOCK™** provides a unique sample system approach that virtually eliminates all potential leak paths while optimizing flow efficiencies. The sample system & flow efficient sensor pocket are machined directly into a solid metallic block and interconnected with small diameter, precision-drilled, intersecting gas passages. Finally, we integrate our specially engineered 3-way Selector Valve, a metering valve, pressure sensor and flow meter directly into the machined block. This approach eliminates long lengths of leak-prone tubing, delivers up to a 400% faster measurement response time, and provides front panel access to the sensor while minimizing overall Analyzer size.

PROPRIETARY SENSOR TECHNOLOGY

AMI uses proprietary manufacturing techniques to produce its exclusive electrochemical oxygen sensors. The patented designs produce a sensor that yields an extremely quick response, high reliability and longer product life. AMI's oxygen sensors provide an industry-leading resistance to H_2S , in concentrations up to 500 ppm. This eliminates the need for a maintenance-intensive H_2S scrubber for the sample gas. AMI also puts 100% of our sensors through a battery of performance tests across multiple temperature ranges to insure they meet our strict quality standards.

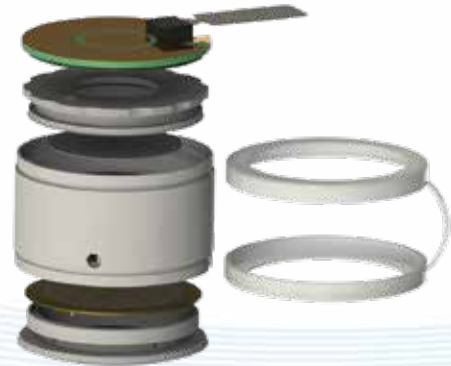

COMMAND CENTER SOFTWARE



AMI's powerful COMMAND CENTER User Interface communicates with all AMI Gas Analyzers. It provides technicians with access to advanced features for configuring and troubleshooting the Analyzer. Users can program alarms to be fail safe or non-fail safe, latching or non-latching, and set as independent alarm delays. They can also access the automatic data logging files, available on all fixed and portable Analyzers. The data logs provide time-stamped records of gas measurement, gas pressure, analyzer temperature and power outage events that can assist with solving intermittent problems.



	T-2	T-4	P-2	P-3	P-4	P-5
Max Range	0 - 10,000 ppm	0 - 10,000 ppm	0 - 50%	0 - 25%	0 - 100%	0 - 25%
Min Range	0 - 5 ppm	0 - 5 ppm	0 - 1,000 ppm	0 - 1,000 ppm	0 - 1.0%	0 - 1,000 ppm
Min Detection	0.05 ppm	0.05 ppm	10 ppm	100 ppm	1,000 ppm	100 ppm
Special Conditions	<10 ppm H ₂ S 100% CO ₂	<500 ppm H ₂ S 100% CO ₂	O ₂ in inert gas	Up to 100% CO ₂	Enriched Oxygen	<500 ppm H ₂ S 100% CO ₂

AMI uses proprietary manufacturing techniques to produce its patented electrochemical oxygen sensors. Every sensor manufactured in our Costa Mesa, CA facility undergoes a battery of performance tests, including response times, noise, drift and linearity across multiple temperature ranges, to insure they meet our strict quality standards.

Note: For high CO₂ background gas, the O₂ Analyzer must include additional programming at the factory.

H₂S SENSORS



**WIDE RANGE
H₂S SENSOR**

Sensor Type	Low Range	High Range
Max Range	0 - 200 ppm	0 - 2000 ppm
Min Range	0 - 10 ppm	0 - 100 ppm
Min Detection	0.1 ppm	0.1 ppm

ACCESSORIES

PRE-CONDITIONING

AMI's pre-conditioning accessories provide protection from liquids, such as glycol, water, compressor oils or other fluids, that can damage an Analyzer. Vertically-mounted Demisters reduce saturated gas temperature and condense out liquids. The LRP's unique membrane allows gas flow while preventing liquids from passing through.



DEMISTER II



**LRP
with DEMISTER**



LRP



**LRP WITH
REGULATOR**

PROTECTION

For applications in extreme cold weather down to -40°F or harsh environmental conditions.



**EXTREME WEATHER
ENCLOSURE**



PROTECTIVE CARRY CASE

SAMPLE PUMPS

Sample pumps draw sample in ambient pressure applications or pressure down to -7 psig. Designed to meet Class I, Div 2, Groups C & D requirements.



**FIXED
SAMPLE PUMP**



**PORTABLE SAMPLE
PUMP**